

## Electronic Process Sensors Electronic Switching and Control Control Products



Protecting, controlling and improving the quality, reputation, safety and reliability of the product you sell, or the equipment you operate, is not a short-term obligation for E-T-A - it's a lifetime commitment. From the moment you take delivery of our control products, you will begin to enjoy the benefits of our innovative thinking.

E-T-A was founded in the late 1940's to develop, manufacture and market electrical and electronic equipment of the highest quality. The founders of the company and their successors have remained loyal to their original principles. These principles allow E-T-A to offer products that are precision-manufactured, perform second-to-none, and fit the ever-increasing number of applications created by advancing technology.

In today's challenging global market, E-T-A control products can give your new product and processes the competitive edge. The reality is, whatever your world - automation, medical, telecommunications, process controls, transportation, or aerospace - you can't afford to be limited in your choices.

That's why the world turns to us. With a complete range of products, we deliver what you demand: a world of solutions. Turn to the best resource in the world for Control Solutions, E-T-A.

E-T-A Products, in controls and automation technology, chemical and machinery industries, process control, and telecommunications equipment, demand uncompromising standards of performance and reliability. The E-T-A products which are widely specified for these applications include: flow meters, flow monitors, level sensors, electronic circuit breakers and SSRPCs.

The needs of environmental protection systems and information technology hardware also represent rapidly growing market sectors for every type of E-T-A product.

**Call E-T-A to request a free Control Products Catalogue.**



[www.e-t-a.com](http://www.e-t-a.com)

Also available is E-T-A's full circuit protection catalogue. The most comprehensive guide to circuit protection and control in the world. With 400 pages and nearly 300,000 different configurations, E-T-A is the best resource in the world for circuit protection.

Most importantly, E-T-A is the only supplier to offer all four circuit protection technologies, thermal, thermal-magnetic, magnetic and high performance circuit breakers. With this complete line, E-T-A will provide you with a precise match for your application, regardless of the technology.

This assures your designs are protected.

**Call E-T-A to request a free Circuit Protection CBE Catalogue.**

All dimensions without tolerances are for reference only. In the interest of improved design, performance and cost effectiveness the right to make changes in these specifications without notice is reserved. Product markings may not be exactly as the ordering codes. Errors and omissions excepted.



## Flow Meters

Application of Flow Meters and Flow Monitors	4
FM1-CA	5
FM1-LQ	5
FM1 / FM1-CC	6
Monitoring head CST-..	7
Monitoring head CSP-..	7
Monitoring head CSF-..	8
Cable types	8
Sensor adapter TP, BV	9
FM1-Ex	10
Monitoring head CST-Ex	11



## Flow Monitors

FM3	12
FS10	13
SW112	14
SW118	14
SW119	15
SW201	15



## Level Sensors

Application of Level Sensors	16
TLS100	17
NR80	17
NR100	18
NR150	18
NR160	19



## Electronic Circuit Breakers

Application of Electronic Circuit Breakers	20
ESS20 for Module 17plus	21
Accessories for ESS20	22
ESS20-003 for SVS02	22

## Solid State Remote Power Controllers (SSRPCs)

Application of Solid State Remote Power Controllers	23
E-1048-60.	24
E-1048-7..	24
E-1048-8C.	25
E-1048-8I.	25
E-1048-8D.	26
E-1071-603	27
E-1072-100	27

## Condensed Selector Chart

For liquids:	<b>FM1-LQ, FM1, FM1-CC, FS10, SW118, SW119, SW201,</b>
For air/gas:	<b>FM1-CA, FM1, FM1-CC, FM3, FS10, SW112, SW118, SW119, SW201</b>
For hazardous areas (combustible media):	<b>FM1-Ex</b>
For granules (powders):	<b>SW118, SW119, SW201</b>



## Applications

Applications for E-T-A flow monitors and meters extend across the entire industrial spectrum including:

- Volume and mass flow measurement of liquids and gases
- Air conditioning systems, radiators and filtration equipment
- Gas and exhaust monitoring systems in heating and power plants, blast furnaces, and gas supply systems
- Welding equipment
- Food processing, brewing and dairy product applications
- Water and waste treatment plant
- Paper manufacturing
- Petrochemical processing
- Pump monitoring and protection
- Control of lubricating, hydraulic and cooling systems
- Agricultural equipment
- Marine and transportation requirements
- Leakage detection and compressed-air consumption measurement

## Operating principle

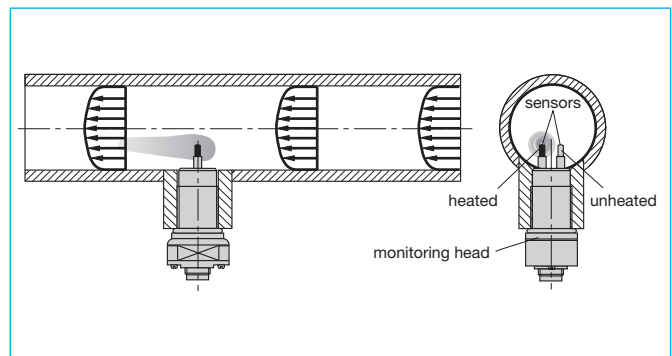

## Typical applications

- Process control
- Climatic engineering
- Power plants
- Water supply
- Compressed-air supply
- Process engineering
- Automotive systems
- Mechanical engineering – cooling systems, protective gas

Advantages of the calorimetric measuring principle

1. Widespread applications: Suitable even for highly contaminated liquids, slurries, solid matters, powdered and granular media, gases and vapours. Once adjusted to the applicable medium, the switching point need not be readjusted.
2. Flow proportional measurement.
3. High dependability: No moving parts in the flowstream, no wear, maintenance-free.
4. Mass flow measurement.
5. High resolution.
6. Wide dynamic range: > 100:1.
7. Excellent repeatability.
8. Independent of viscosity, electrical conductivity.
9. Wide pipe diameter range.



# Flow Meter FM1-CA



The micro controller operated Flow Meter FM1-CA for air, compressed air, oxygen, nitrogen (other gases upon request). It is particularly suited to consumption measurement and leakage detection in compressed air systems. Suitable for use with calorimetric monitoring heads CSP-11A.. and CSF-11A...

**FM1-FH-CA ( surface mounted housing)**

### Technical data

Temperature range	+10 °C...+50 °C (ambient temp.)
Input voltage	DC 24 V (19...32 V)
<b>Flow</b>	
Measuring range	0...68 Nm <sup>3</sup> /s in TP-01 0-50 (70) Nm <sup>3</sup> /h in TP-06 0-480 (685) Nm <sup>3</sup> /h
<b>Temperature</b>	
Measuring range	-40 °C...+130 °C (medium temperature)

### Features

- See FM1

### Ordering information

Type	
<b>FM1-CA</b>	Flow Meter with software for mass measurement of gases, rail mounted
<b>FM1-FH-CA</b>	Flow Meter with software for mass measurement of gases, surface mounted
<b>FM1-ST-CA</b>	Flow Meter with software for mass measurement of gases, front panel mounted
Input voltage	
<b>U1</b>	DC 19...32 V
Signal outputs	
<b>R2</b>	2 relay outputs (2 limit values)
<b>T4</b>	4 transistor outputs (2 limit values + 2 status, or 2 limit values + 1 status + 1 pulse output)
Analogue outputs	
<b>V1</b>	0/1- 5 Volt
<b>V2</b>	0/2-10 Volt
<b>C1</b>	0/4-20 mA (self-powered, physically isolated)
<b>FM1-CA - U1 R2 V1</b>	ordering example



# Flow Meter FM1-LQ

Micro controller operated flow meter for water (other liquids upon request). Particularly suited to volume flow measurements with simultaneous measurement of medium temperature. Suitable for use with calorimetric monitoring heads CSP-11W.. and CSF-11W...

**FM1-ST-LQ (front panel mounted housing)**

### Technical data

Temperature range	+10 °C...+50 °C (ambient temp.)
Input voltage	DC 24 V (19...32 V)
<b>Flow</b>	
Measuring range	0.05...3 m/s in TP-01 0.02-2.2 (2.9) m <sup>3</sup> /h in TP-06 0.2-21.2 (28.3) m <sup>3</sup> /h
<b>Temperature</b>	
Measuring range	-40 °C...+130 °C (medium temperature)

### Features

- See FM1

### Ordering information

Type	
<b>FM1-LQ</b>	Flow Meter with software for water, rail mounted
<b>FM1-FH-LQ</b>	Flow Meter with software for water, surface mounted
<b>FM1-ST-LQ</b>	Flow Meter with software for water, front panel mounted
Input voltage	
<b>U1</b>	DC 19...32 V
Signal outputs	
<b>R2</b>	2 relay outputs (2 limit values)
<b>T4</b>	4 transistor outputs (2 limit values + 2 status, or 2 limit values + 1 status + 1 pulse output)
Analogue outputs	
<b>V1</b>	0/1- 5 Volt
<b>V2</b>	0/2-10 Volt
<b>C1</b>	0/4-20 mA (self-powered, physically isolated)
<b>FM1-LQ - U1 R2 V1</b>	ordering example



Micro controller operated Flow Meters to monitor and display flow rates and temperature. Factory pre-set for air and water. Suitable for use with calorimetric monitoring heads CST-01..., CSP-01... and CSF-01....

### FM1-CC (Customer Calibration):

The characteristic curve for water (with monitoring head CST and CSF) has been stored as standard. Please specify when ordering if a different curve or different medium is required (e. g. for air or oil).

Higher accuracy as the exact characteristic curve of the connected calorimetric monitoring head is recorded in the software (= medium classification).

### FM1 (rail-mounted housing)

### Ordering information

Type	
<b>FM1</b>	Flow Meter, in rail-mounted housing (standard software version)
<b>FM1-CC</b>	Flow Meter, in rail-mounted housing (CC- software version)
<b>FM1-FH</b>	Flow Meter, in surface mounted housing (IP64)
<b>FM1-FH-CC</b>	Flow Meter, in surface mounted housing (IP64)
<b>FM1-ST</b>	Flow Meter, in front panel mounted housing (IP65)
<b>FM1-ST-CC</b>	Flow Meter, in front panel mounted housing (IP65)
Input voltage	
<b>U1</b>	DC 19...32 V
Signal outputs	
<b>R2</b>	2 relay outputs (2 limit values)
<b>T4</b>	4 transistor outputs (2 limit value + 2 status, or 2 limit value + 1 status + 1 pulse output (menu-selected))
Analogue outputs	
<b>V1</b>	0/1- 5 V
<b>V2</b>	0/2-10 V
<b>C1</b>	0/4-20 mA (self-powered, physically isolated)
Specification of medium	
<b>xxx</b>	
<b>FM1 - U1 R2 V1 - ...</b>	ordering example

### Technical data

Temperature range +10 °C...+50 °C (ambient temp.)  
 Input voltage DC 24 V (19...32 V)

### Flow

Measuring range  
 Water: 0.05...3 m/s  
 Air: 0.1...20 m/s  
 Oil: 0.05...5 m/s (only FM1-CC, upon request)

### Temperature

Measuring range -40 °C...+130 °C (medium temperature)

### Features

- Menu driven (keypads)
- LC display (2 x 16 digits) of:
  - actual flow rate, volume flow or mass flow, medium temperature;
  - bargraph status indication of limit contacts, actual flow rate/quantity or medium temperature
  - directions for parameter assignment, configuration, diagnosis and error correction;
  - base value indication
- Two scalable analogue outputs (flow and temperature)
- Peak memory (MIN + MAX)
- Two freely selectable limit contacts
- Quantity-related pulse output
- Versions for rail, front panel and surface mounting

### FM1 (rail-mounted housing)

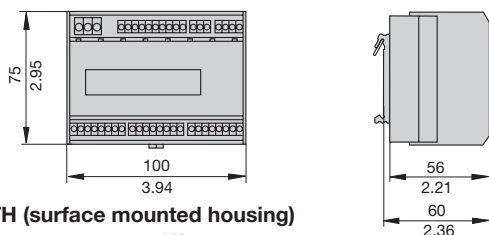

### FM1-FH (surface mounted housing)

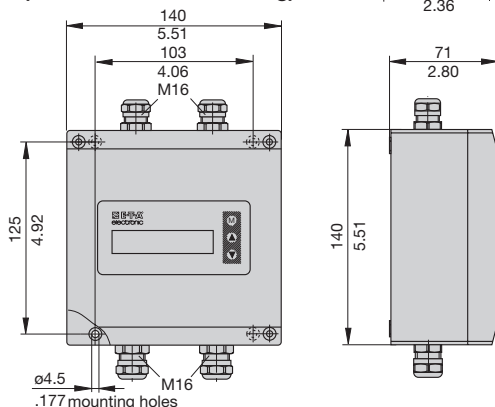

### FM1-ST (front panel mounted housing)

mounting hole  
DIN 43700

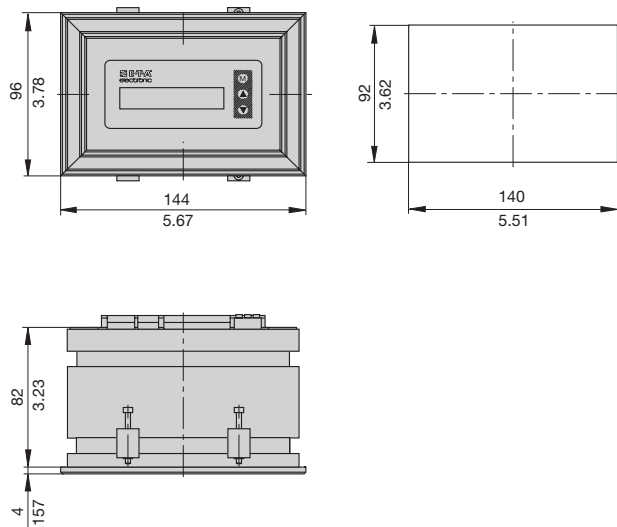

This is a metric design and millimeter dimensions take precedence (mm / inch)



# Monitoring head CST-..



Thread-mounted calorimetric monitoring head for Flow Meter FM1, FM1-CC suitable for general industry applications.

## Features

- Suitable for installation in welding bushes
- Medium temperature -40 °C...+130 °C
- Material: stainless steel 1.4571/AISI 316 Ti, or Hastelloy alloy C4 2.4610

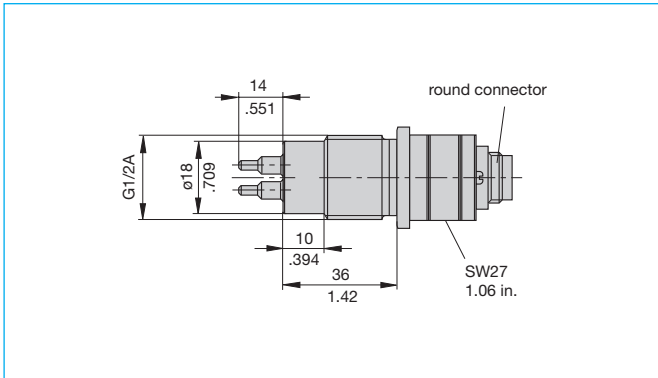

## Ordering information

<b>Type No.</b>	
<b>CST</b>	Thread-mounted monitoring head with calorimetric sensors
<b>Process connection</b>	
<b>01</b>	thread size G1/2A (FM1, FM1-CC)
<b>Medium</b>	
<b>A</b>	air
<b>W</b>	water
<b>S</b>	other media, e.g. oil (FM1-CC only)
<b>Material of areas exposed to medium</b>	
<b>M1</b>	stainless steel 1.4571/AISI 316 Ti (standard)
<b>M2</b>	nickel-based alloy Hastelloy alloy C4 2.4610
<b>Length of shank/thread</b>	
<b>L10</b>	36 mm (standard)
<b>Electrical connection</b>	
<b>E10</b>	round connector with tinned contacts (plug and cable to separate order)
<b>Certification</b>	
<b>T0</b>	without certificate (standard)
<b>Specification of medium</b>	
xxx	
<b>CST - 01 W M1 L10 E10 T0 - ...</b>	ordering example



# Monitoring head CSP-..

Calorimetric plug-in type monitoring head for sensor adapter TP/BV and flow meter FM1-CC, FM1-CA and FM1-LQ.

The monitoring head CSP is installed in sensor adapter TP or ball valve BV.

## Features

- Ease of installation (sensor adapter TP/ball valve BV)
- Small physical size
- Medium temperature range -40°C...+130°C
- Material: stainless steel 1.4571/AISI 316 Ti
- Sealing: Viton O ring

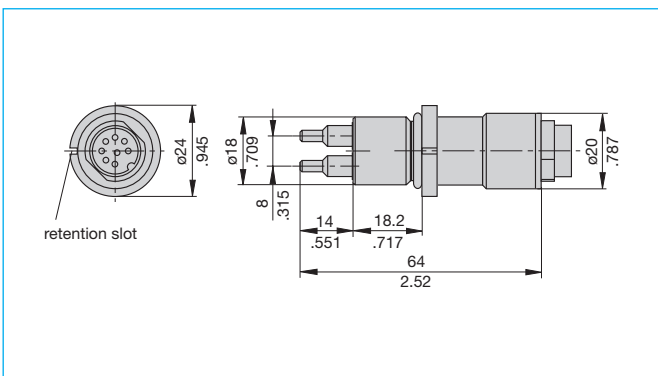

## Ordering information

<b>Type</b>	
<b>CSP</b>	plug-in type monitoring head with calorimetric sensors
<b>Process connection</b>	
<b>01</b>	plug-in type (FM1-CC)
<b>11</b>	plug-in type (FM1-CA; FM1-LQ)
<b>Medium</b>	
<b>A</b>	air (FM1-CA)
<b>W</b>	water (FM1-LQ)
<b>S</b>	all media, e.g. oil (please enquire) (FM1-CC)
<b>Material of areas exposed to medium</b>	
<b>M1</b>	stainless steel 1.4571/AISI 316 Ti
<b>Length of shank/thread</b>	
<b>L05</b>	18.2 mm (standard)
<b>Electrical connection</b>	
<b>E10</b>	round connector with tinned contacts (plug and cable to separate order)
<b>Certification</b>	
<b>T0</b>	without certificate (standard)
<b>Specification of medium</b>	
xxx	
<b>CSP - 11 S M1 L05 E10 T0 - ...</b>	ordering example

Extended calorimetric monitoring head with variable immersion depth for Flow Meter FM1-xxx, suitable for use in compressed air systems or water pipes > DN 50 (2")... DN 500.



## Ordering information

<b>Type</b>	
<b>CSF</b>	Extended monitoring head with calorimetric sensors
<b>Monitoring head design</b>	
<b>01</b>	Monitoring head with variable immersion depth (FM1, FM1-CC)
<b>11</b>	Monitoring head with variable immersion depth (FM1-CA, FM1-LQ)
<b>Medium</b>	
<b>A</b>	air
<b>W</b>	water
<b>Material of areas exposed to medium</b>	
<b>M1</b>	stainless steel 1.4571/AISI 316 Ti
<b>Process connection</b>	
<b>00</b>	without flange; see accessoires for cable gland
<b>Length of shank/thread</b>	
<b>L43</b>	188 mm (standard with process connection 00) other lengths upon request
<b>Electrical connection</b>	
<b>E10</b>	round connector with tinned contacts (plug and cable to separate order)
<b>Certification</b>	
<b>T0</b>	without certificate standard
<b>Specification of medium</b>	
<b>xxx</b>	
<b>CSF - 11 A M1 00 L43 E10 T0 - ...</b>	ordering example

## Features

- Medium temperature range: -40 °C...+130 °C
- Material: stainless steel 1.4571/AISI 316 Ti
- Accessories to install the CSF are also available (e.g. threaded installation bush)

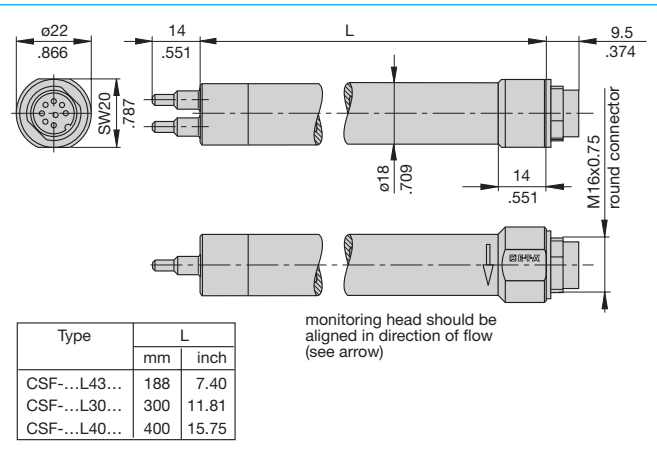

This is a metric design and millimeter dimensions take precedence (  $\frac{\text{mm}}{\text{inch}}$  )

## Cable types

Cable between Flow Meter FM1-xxx and calorimetric monitoring head type CST, CSP, CSF.



- Connection to monitoring head by means of 8-pole round connector
- Connection to FM1-xxx by means of 10-pole clamping connector (XSK)

## Ordering information

<b>Type</b>		between calorimetric monitoring heads and <b>FM1-xxx</b>
<b>Do + Ka type 15</b>	<b>PVC</b> insulated cable, type LifYCY 4x2x0.2 mm <sup>2</sup> (AWG 24)	8-pole round connector + 10-pole clamping connector
<b>Do + Ka type 18</b>	<b>silicone</b> insulated cable, type 4x2x0.2 mm <sup>2</sup> (AWG 24)	8-pole round connector + 10-pole clamping connector
<b>Available cable lengths</b>		
<b>...m</b>	2 m, 3 m, 5 m, 8 m, 10 m, 15 m, 20 m, 25 m, 30 m, 40 m, 50 m, 60 m, 70 m, 80 m, 90 m, 100 m, 110 m, 120 m, 130 m, 140 m, 150 m, 160 m, 170 m, 180 m, 190 m, 200 m	
<b>Do + Ka type 15 - 2 m</b>	ordering example	

## Technical data

<b>Cable type 15</b>	
<b>Features:</b>	highly flexible, paired, fully shielded, electrical and thermal properties at +20 °C
<b>Conductor resistance:</b>	< 92 $\Omega$ /km
<b>Insulation resistance:</b>	> 200 M $\Omega$ /km
<b>Operating voltage:</b>	max. 100 V AC
<b>Withstand voltage:</b>	AC 800 V
<b>Max. load:</b>	0.5 A
<b>Temperature range:</b>	-10 °C...+80 °C (processing and operation) -30 °C...+80 °C (transport and storage)

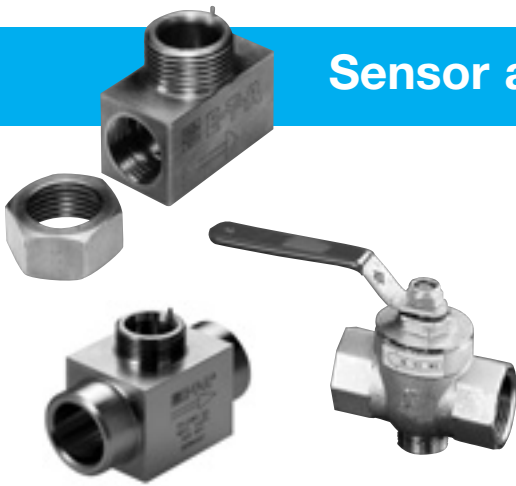

Sensor adapters TP and BV facilitate correct positioning and exchange of CSP monitoring heads, Flow monitors FM3 or FS10 in pipes with process connection DN 15...DN 50. Ball valve BV enables pressure-free installation or removal of CSP monitoring heads and Flow monitors FM3 and FS10 simply by closing the input and output pipe. The measuring points are suited to temporary measurements; after completion of the measuring cycle they can be closed by means of blanking plugs.

## Features

- Correct positioning of sensor CSP or flow monitors FM3/FS10
- Ease of sensor replacement
- Measuring point can be closed if not used
- Sensor adapter TP available as screw-in or welding type
- Ball valve BV also serves as a shutoff valve (both input and output)

### TP... Sensor adapter with internal thread

Material stainless steel (-M1): PN 315 bar / 4630.5 PSI  
 Material brass (-M3): PN 25 bar / 367.5 PSI  
 Material red brass (-M5): PN 16 bar / 235.2 PSI

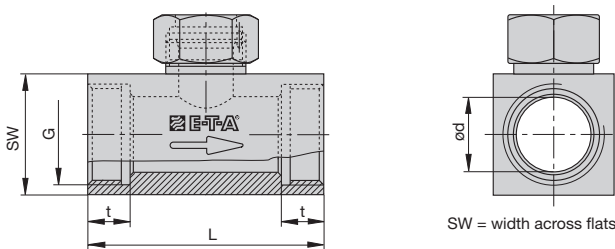

SW = width across flats

### TP...M1-SA Sensor adapter with welding nipples

PN 315 bar / 4630.5 PSI

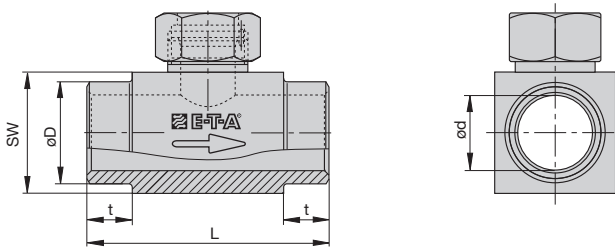

### BV...M3 Ball valve with internal thread

PN 25 bar / 367.5 PSI

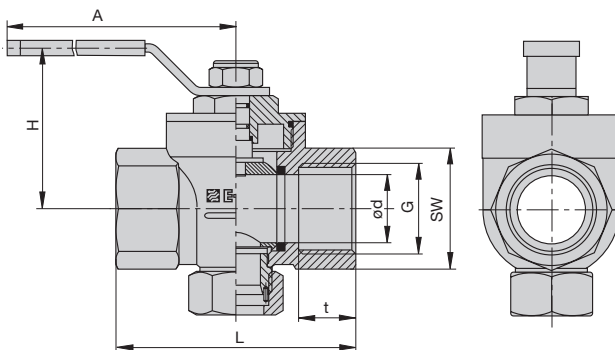

## Ordering information

Type	
TP	Sensor adapter with internal thread
<b>Process connection/Nominal size</b>	
01	DN 15 G1/2 internal thread length: 50 mm
02	DN 20 G3/4 internal thread length: 64 mm
03	DN 25 G1 internal thread length: 78 mm
04	DN 32 G1 1/4 internal thread length: 94 mm
05	DN 40 G1 1/2 internal thread length: 110 mm
06	DN 50 G2 internal thread length: 138 mm
<b>Material of the area exposed to medium</b>	
M1	stainless steel 1.4571/AISI 316Ti PN 315 bar
M3	brass (not TP-03..) PN 25 bar
M5	red brass (only TP-03..) PN 16 bar
TP - 01	M3 ordering example

## Ordering information

Type	
TP	Sensor adapter with welding nipples
<b>Process connection/Nominal size</b>	
01	DN 15 dia.d: 16 mm length: 80 mm
02	DN 20 dia.d: 20 mm length: 70 mm
03	DN 25 dia.d: 25 mm length: 80 mm
04	DN 32 dia.d: 32 mm length: 100 mm
05	DN 40 dia.d: 40 mm length: 110 mm
06	DN 50 dia.d: 50 mm length: 140 mm
<b>Material of the area exposed to medium</b>	
M1	stainless steel 1.4571/AISI 316Ti
<b>Process connection</b>	
SA	welded connection
TP - 01	M1 - SA ordering example

## Ordering information

Type	
BV	ball valve with internal thread
<b>Process connection/Nominal size</b>	
03	DN 25 G1 internal thread length: 88 mm
04	DN 32 G1 1/4 internal thread length: 100 mm
05	DN 40 G1 1/2 internal thread length: 110 mm
06	DN 50 G2 internal thread length: 131 mm
<b>Material of the area exposed to medium</b>	
M3	nickel plated brass, Delrin seal
BV - 03	M3 ordering example

This is a metric design and millimeter dimensions take precedence (mm/inch)



The FM1-Ex has been designed to provide monitoring, detection and indication of flow speed, flow volume and medium temperature of liquids, gases and powders, also suitable for use as a mass flow meter.

The FM1-Ex meets the requirements of EC directive 94/9/EG (ATEX 100 a) in combination with the calorimetric monitoring head CST-Ex-..

**The control unit FM1-Ex is not designed for use in explosive atmospheres. The CST-Ex monitoring head is suitable for Zone 0 or Zone 20 installation.**

## Technical data

Temperature range	+10 °C...+43 °C
Input voltage	DC 24 V (19...32)
<b>Flow</b>	
Measuring range	Water: 0.05...3 m/s Oil: 0.05...5 m/s Air: 0.1...20 m/s
<b>Temperature</b>	
Measuring range	-40 °C...+75 °C
Degree of protection	IP54

## Features

- Menu driven (keypads)
- LCD-display (2 x 16 digits) of:
  - indication of actual flow rate, volume flow or mass flow, medium temperature;
  - bargraph status indication of limit contacts, actual flow rate/flow quantity and/or medium temperature;
  - directions for parameter assignment, configuration, diagnosis and error correction;
  - peak value indication
- Two scalable analogue outputs
- peak value memory (MIN + MAX)
- Two freely selectable limit contacts
- Quantity related pulse output - counter connection/transistor drive.

## Ordering information

Type	
<b>FM1-Ex</b>	Flow Meter, surface mounted (IP54)
	<b>Input voltage</b>
	<b>U1</b> DC 24 V (19...32 V)
	<b>Signal outputs</b>
	<b>R2</b> 2 relay outputs (2 limit value)
	<b>T4</b> 4 transistor outputs (2 limit value + 2 status indication)
	<b>Analogue outputs</b>
	<b>V1</b> 0/1-5 Volt
	<b>V2</b> 0/2-10 Volt
	<b>C1</b> 0/4-20 mA (self-powered, physically isolated)
	<b>Certification</b>
	<b>T5</b> approval to EC directive 94/9/EG (ATEX 100 a)
	<b>Specification of medium</b>
	<b>xxx</b>
<b>FM1-Ex - U1 R2 V1 - T5 ...</b>	ordering example

### FM1-Ex (surface mounted)

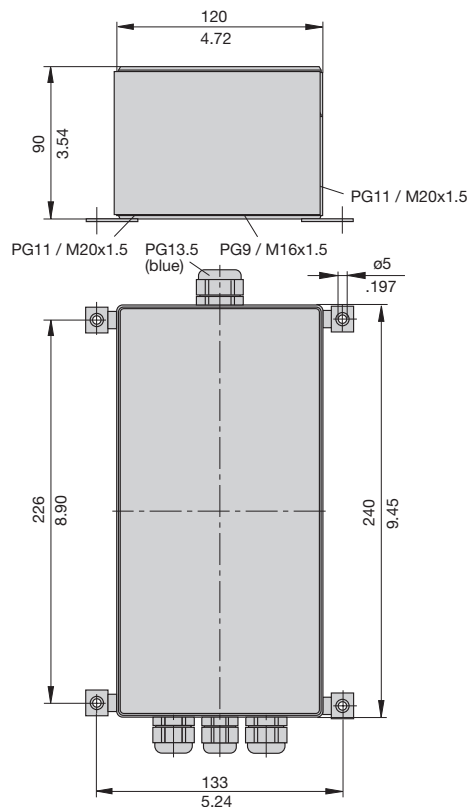



Thread-mounted ex-approved calorimetric monitoring head for Flow Meter FM1-Ex. For use in hazardous areas in equipment group II, category 1 (zones 0 and 20 installation).

EC type test certificate to EN 50014, EN 50020, EN 50281-1-1, EN 50284 and EN 1127-1 type of protection  $\text{\textcircled{C}}$  II (1) 1/2 GD T 130 °C IP67 EEx ia IIC T4.

## Features

- Medium temperature -40°C...+75°C
- material monitoring head:
  - stainless steel 1.4571/AISI 316 Ti
  - Hastelloy C4 2.4610
  - Titanium G7 3.7235
- In conformance with EN 50014 and EN 50020

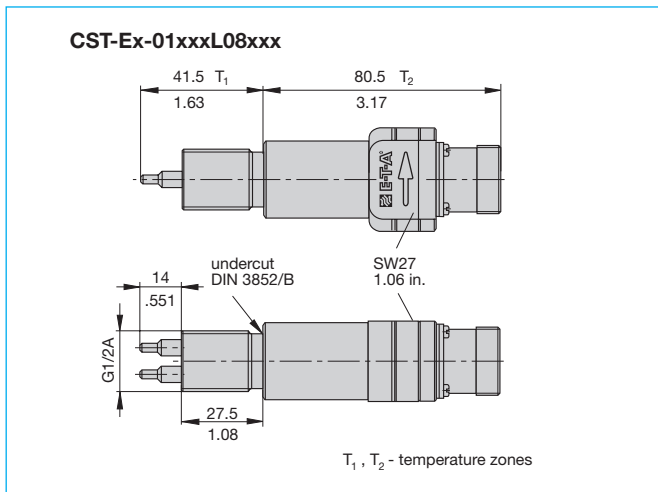

## Ordering information

<b>Type</b>	Thread-mounted monitoring head with calorimetric sensors
<b>CST-Ex</b>	
<b>Process connection</b>	
<b>01</b>	thread size G1/2A
<b>Medium</b>	
<b>A</b>	air
<b>W</b>	water
<b>S</b>	other media e. g. oil (please enquire)
<b>Material of areas exposed to medium</b>	
<b>M1</b>	stainless steel 1.4571/AISI 316 Ti (standard)
<b>M2</b>	Hastelloy C4 2.4610
<b>M6</b>	Titanium G7 3.7235
<b>Length of shank/thread</b>	
<b>L08</b>	27.5 mm (standard)
<b>L10</b>	36 mm
<b>Electrical connection</b>	
<b>E20</b>	round connector with tinned contacts
<b>Certification</b>	
<b>T5</b>	approval to EC directive 94/9/EG (ATEX 100 a)
<b>Specification of medium</b>	
<b>xxx</b>	
<b>CST-Ex - 01 W M1 L08 E20 T5 - ...</b>	ordering example

## Cable type



Cable between Flow Meter FM1-Ex and calorimetric monitoring head CST-Ex.

- Connection to monitoring head by means of 12-pole round connector
- Connection to FM1-Ex: wire end ferrules for connection to ex-barriers

## Technical data

### Cable type 17

**Features:** paired control line, fully shielded, light-blue insulation, for intrinsically safe systems, electrical and thermal properties at +20 °C

Conductor resistance:	< 25 Ω/km
Insulation resistance:	> 200 MΩ/km
Capacity (wire/wire/grounded shield)	110 pF/m ± 20 %
Operating voltage (VDE 0812)	max. 500 V AC
Test voltage (wire/wire/shield)	1200 V AC
Temperature range:	-10 °C...+80 °C (operation) -30 °C...+80 °C (transport and storage)

## Ordering information

<b>Type</b>	between calorimetric monitoring heads <b>CST-Ex</b> and <b>FM1-Ex</b>
<b>Do + Ka type 17</b>	<b>PVC</b> -insulated cable, type LifYCY 4x2x0.75mm <sup>2</sup> (AWG 18) 12-pole round connector + wire end ferrules
<b>Available cable lengths</b>	
<b>...m</b>	2 m, 3 m, 5 m, 8 m, 10 m, 15 m, 20 m, 25 m, 30 m, 40 m, 50 m
<b>Do + Ka type 17 - 2 m</b>	ordering example



The miniature Flow Monitor FM3 is designed to operate with compressed air, oxygen and nitrogen. With one analogue output, one frequency output or one flow limit value. Sensor head with integral electronic circuitry.

When used in a compressed-air system, the FM3 should be installed behind the air dryer to prevent moisture condensation of the sensors. Suitable filtering measures should be adapted to prevent damage to the ceramic sensors by particles in the pipeline.

## Ordering information FM3

<b>Type</b>	
<b>FM3</b>	Miniature Flow Monitor with 4 pole connector
<b>Process connection</b>	
<b>11</b>	Insertion-type
<b>Material of the area exposed to medium</b>	
<b>M1</b>	stainless steel 1.4571/AISI 316 Ti, polyamide/ceramics/glass-passivated sealing
<b>M3</b>	brass, polyamide/ceramics, glass-passivated sealing
<b>Length of shank</b>	
<b>L05</b>	19 mm (standard)
<b>L15</b>	120 mm (without O ring, without O ring groove)
<b>Electrical connection</b>	
<b>E08</b>	IEC947 M8
<b>Output</b>	
<b>C11</b>	analogue output 4...20 mA
<b>F1</b>	frequency output 25-100 Hz
<b>F2</b>	frequency output 0-100 Hz
<b>R1</b>	1 relay output, 1 MIN switch point
<b>Measuring range</b>	
<b>MB0</b>	low, analogue output only
<b>MB1</b>	medium, analogue output only
<b>MB2</b>	high, analogue or relay output
<b>FM3 - 11 M1 L05 E08 C11 - MB1 ordering example</b>	

## Ordering information

<b>Cable and cable connector</b>	
<b>Do + Ka type 21 - 5 m</b>	with connector to IEC 60947-5-2, 4-pole M8 and PUR insulated cable 4x0.34 mm <sup>2</sup> (AWG 22)
<b>Do + Ka type 21 - 5 m</b>	ordering example

## Sensor adapter TP-... / Ball valve BV-...

technical data see page 9

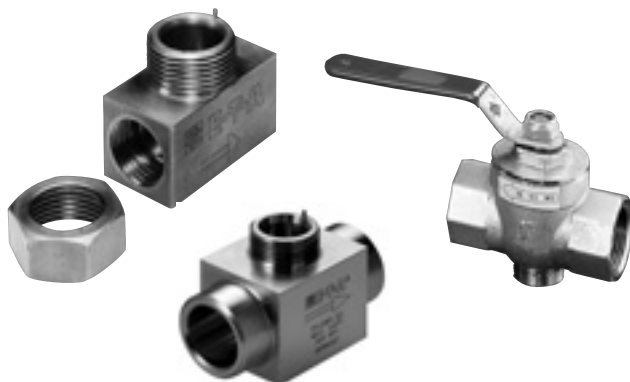

TP-...

BV-...

## Features

- Pressure resistant,  $p_N = 16 \text{ bar}/235.2 \text{ PSI}$
- Installation by sensor adapter TP-... or ball valve BV-...
- Connection by means of M8 connectors to IEC 60947-5-2
- Operating range factory pre-set
- Adjustable limit value
- No moving parts in the flow stream
- LED status indication
- Relay or analogue output
- **Flow**  
Measuring range 0...68 Nm/s e. g. with option -MB2:  
in TP-01 0...50 Nm<sup>3</sup>/h  
in TP-06 0...480 Nm<sup>3</sup>/h

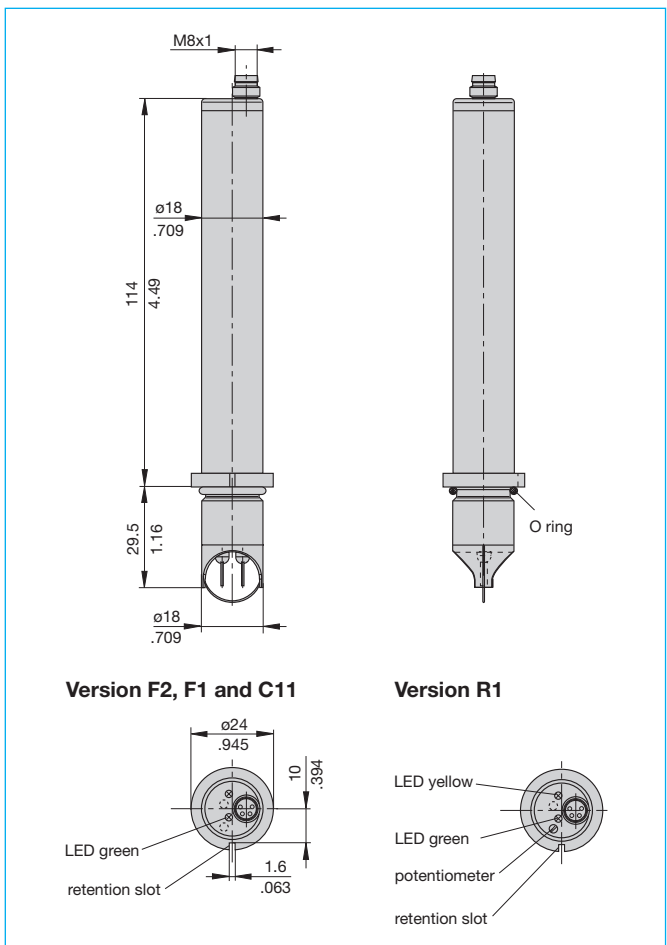

This is a metric design and millimeter dimensions take precedence ( $\frac{\text{mm}}{\text{inch}}$ )



Compact single point flow monitor, MIN or MAX monitoring options, suitable for water, oil, air or media with similar thermal conductivities. With screw-in or plug-in type monitoring head for ease of installation and correct positioning.

If the flow rate falls below (MIN) or exceeds (MAX) the pre-adjusted value, the signal output will be switched and the yellow LED will light.

## Features

- wear-resistant compact design, with stainless steel 1.4571 monitoring head and housing
- switch point steplessly adjustable by means of potentiometer
- status indication by green LED
- media temperature range  $-25^{\circ}\text{C} \dots +100^{\circ}\text{C}$
- M12 plug-in electrical connection
- LED fault indication
- signal output with HighSide-FET output
- protected against short circuits and overloads
- flow specification: air 0.5...50 m/s  
water, oil 0.01...4.5 m/s

## Sensor adapter TP-... / Ball valve BV-...

technical data see page 9

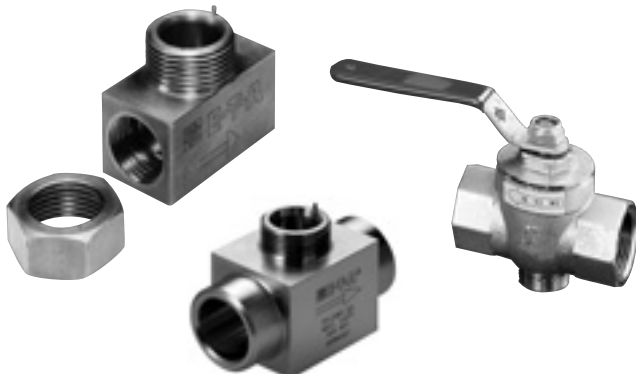

TP-...

BV-...

## Ordering information

<b>Flow monitor (calorimetric)</b>	
<b>FS10</b>	flow monitor and integral compact housing
<b>Power supply</b>	
<b>U1</b>	DC 24 V
<b>Flow switch point</b>	
<b>MIN</b>	
<b>MAX</b>	
<b>Process connection</b>	
<b>01</b>	G1/2A (to DIN 3852-A), length 36 mm
<b>11</b>	plug-in type (following DIN ISO 6149), length 18.2 mm for adapter TP and BV
<b>Media</b>	
<b>A</b>	air, gases
<b>W</b>	water, oil, liquids
<b>Fitting material</b>	
<b>M1</b>	stainless steel 1.4571/AISI 316 Ti
<b>Electrical connection</b>	
<b>E12</b>	M12x1, 3-pole
<b>Certification</b>	
<b>T0</b>	without certificate
<b>FS10 - U1 MAX 01 W - M1 E12 T0</b>	ordering example

## Ordering information

<b>Cable and cable connector</b>	
<b>Do + Ka type 24 - 5 m</b>	with connector to IEC60947-5-2, 3-pole M12 and PUR insulated cable 3x0.34 mm <sup>2</sup> (AWG 22)
<b>Do + Ka type 24 - 5 m</b>	ordering example

### FS 10-...-01

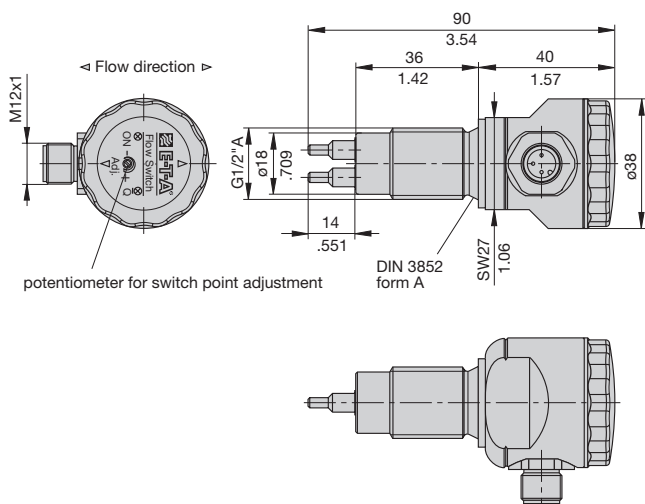

### FS 10-...-11

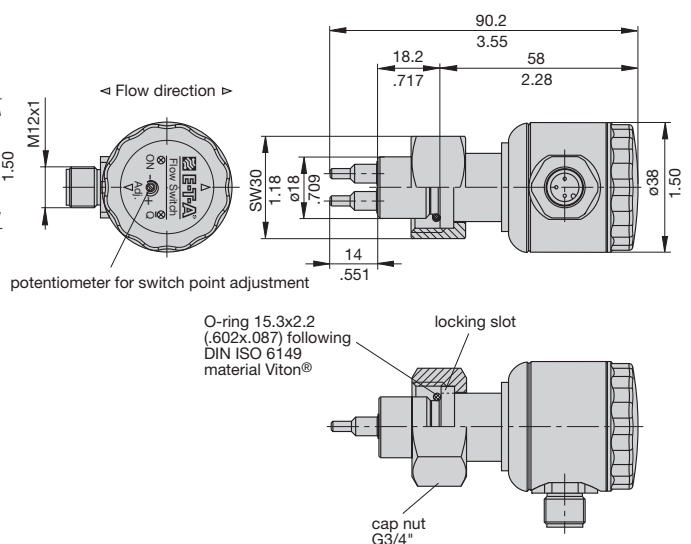





AC or DC operation

# Flow Monitor SW119



Single point flow monitors with change over MIN/MAX monitoring function, suitable for water, oil, air, and media with similar thermal conductivities (selectable by means of a medium switch). With either no delay, or with a 60 s switch-on delay or 10 s change over delay. Medium temperature range: up to +100 °C  
Flow specification: liquids 0.01...4 m/s  
gases 0.5...50 m/s

## Ordering information SW119

### Single Point Flow Monitor

**SW119** for surface mounting, with separate monitoring head

#### Input voltage

**AC 230 V** 50/60 Hz (standard)

**AC 115 V** 50/60 Hz

**AC/DC24 V** (AC: 50/60 Hz)

**SW119 - AC230V** ordering example

### Monitoring head

**MK G1/2A ST12** G1/2A stainless steel 1.4571/AISI 316 Ti

### Cable and plug

between monitoring head and control unit

#### Do + Ka type 2

7-pole round connector, PVC insulated cable type LiYCY 6x0,14 mm<sup>2</sup>/AWG 26, RAL 7032

#### Available cable lengths

...m 2 m, 3 m, 5 m ...100 m

**Do + Ka type 2 - 2 m**

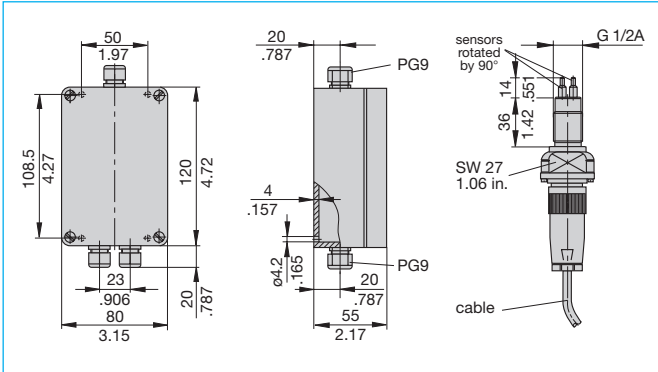

# Flow Monitor SW201

This Flow Monitor operates on the calorimetric principle and is suitable for liquids and gases. With one switch point (MIN function) and trend output and additional temperature monitoring of media.

## Features

- Adjustable to wide range of flow rates
- Temperature monitoring
- No moving parts in the flow stream
- Operation largely independent of pipe diameter
- LED status indication
- Relay output for flow
- Pressure resistant monitoring head
- Fast response time
- Wire break sensing included
- Suitable for liquids of all viscosities and gases
- Analogue output (non-linear)
- Choice of monitoring heads for various applications
- Flow specification: liquids 0.01...5 m/s  
gases 0.5...100 m/s

## Ordering information

### Electronic Control Unit

**SW201** standard version, relays for wire breakage, flow and temperature

#### Supply voltage

**AC 230 V** supply voltage AC 230/240 V, 50/60 Hz

**AC 115 V** supply voltage AC 115 V, 50/60 Hz

**AC/DC24 V** supply voltage AC/DC 24 V

#### Non-linear analogue output

**1** 0...20 mA

**2** 4...20 mA

**SW201 - AC230 V - 1** ordering example

### Monitoring head - standard versions

**MKG1/2A** G1/2" thread (MKG3/4A please enquire)

#### Monitoring head versions

**ST02** for liquids and gases (1.4571/AISI 316 Ti)

**MKG1/2A - ST02** ordering example

### Cable and plug

between monitoring head and control unit

#### Do + Ka type 1

7-pole round connector, PVC insulated cable type LiYCY 6x0,14 mm<sup>2</sup>/AWG 26, RAL 7032

#### Available cable lengths

... m 2 m, 3 m, 5 m...100 m

**Do + Ka type 1 - 2 m**

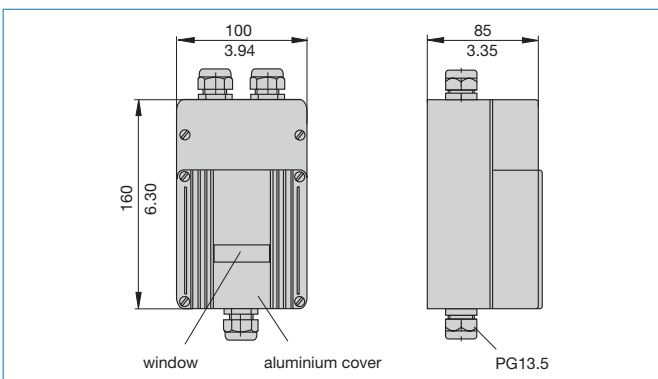

## Condensed Selector chart

Water:	<b>TLS100, NR80, NR100, NR150, NR160</b>
Oil:	<b>NR150, NR200</b>
Granules (powders):	<b>NR100, NR160</b>

E-T-A level sensors are of high quality maintenance free and have a wide operating temperature range. They respond to the change of capacitance occurring when an electrode surrounded by air is immersed in the medium to be monitored. This capacitance change causes a circuit to oscillate which is processed electronically.

The different versions can be used as MIN/MAX sensors with closed circuit principle. Power failure and wire break are indicated the same way as incorrect medium level.



## Application examples

### NR100 for the food industry

Yoghurt paste is removed from fermentation tanks by means of a pump. The pipes must be filled completely with the paste to ensure there is no air in the pipes which may promote microbacterial growth.

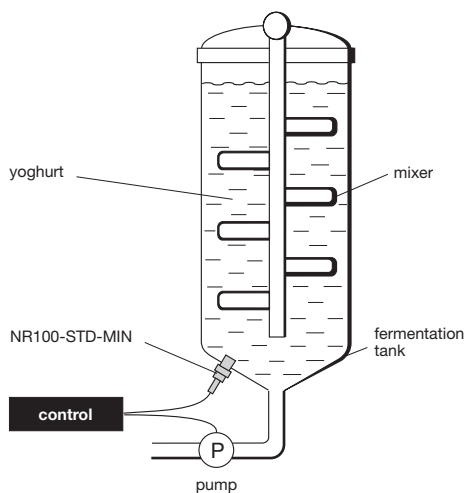

### NR160 - Pump sequence for separation:

- When top level (1) of oil is detected, the waste water pump starts. The waste water pump stops when oil is detected (3). The oil pump starts and pumps until low level oil detector (4) reacts. This stops the action.
- If the water level reaches the oil/water separation detector (2) the waste water pump starts. This pumps until the low oil level is reached (3). This stops the waste water pump.

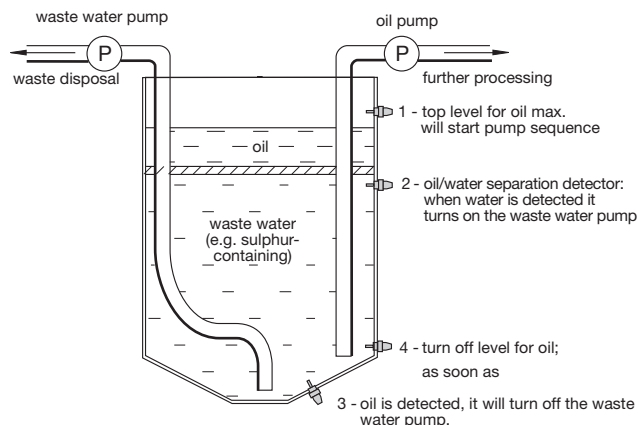

### NR80 in medical equipment

Indication that infusion bottles are empty: To overcome personnel shortages, level sensing of infusion bottles can be provided by Level Sensor NR80 which is able to sense the liquid value through the bottle wall.

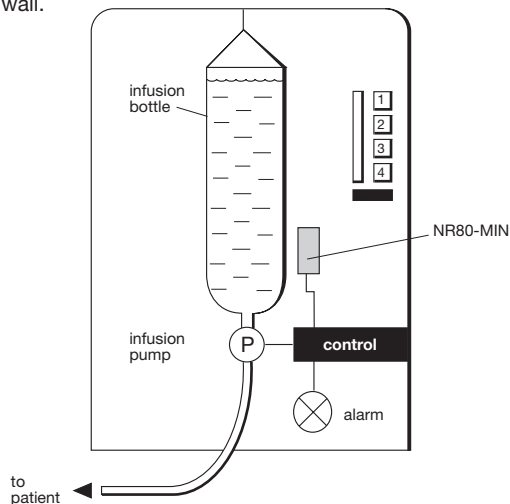

### NR150/160 in process control systems

Low level sensing of oil and cooling water in emergency diesel generator sets.

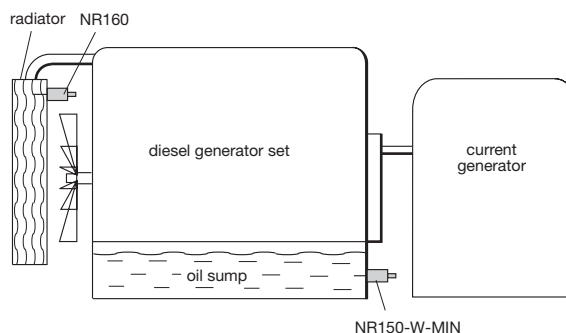



Level Sensor NR100 is designed to monitor liquids, granules, and powder. It is especially suitable for aggressive media and food processing applications. Available as MIN or MAX monitor.



## Features

- MIN or MAX sensor
- transistor output, with short circuit protection, high side switching
- max. medium temperature +130 °C
- adjustable switching point
- LED status indication

## Ordering Information

<b>Type No.</b>	
NR100	sanitary level sensor
<b>Voltage Rating</b>	
DC 24 V	
<b>Mounting method</b>	
STD	for use with compression nut (to be ordered separately)
G1A	thread to DIN 13, part 6, ISO 228/1
1" NPT	thread to ANSI B1.20.1
<b>Probe and fitting material</b>	
B4	PTFE Teflon,
<b>Function (factory preset)</b>	
MIN	minimum sensor
MAX	maximum sensor
<b>Cable (type LVCC, AWG16, 3x1.31 mm<sup>2</sup>)</b>	
standard without cable	
NR100 - DC24V - 1"NPT - B4 - MAX ordering example	

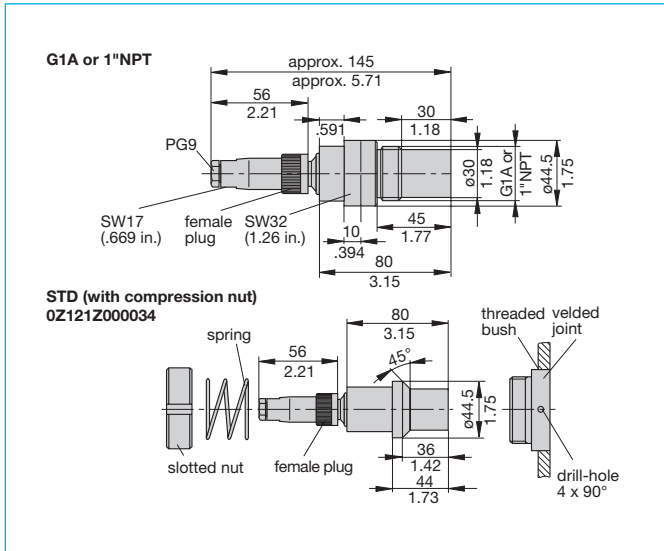

# Level Sensor NR150

Level Sensor NR150 is suitable for liquids with low relative dielectric constant  $\epsilon_r$  (e.g. oil). With MIN/MAX selector switch.



## Ordering Information

<b>Type No.</b>	
NR150	level sensor
<b>Voltage Rating</b>	
DC 9 - 36 V short-circuit proof PNP transistor output	
<b>Mounting method</b>	
G3/4A	thread to DIN 13, part 6, ISO 228/1
3/4" NPT	thread to ANSI B1.20.1
<b>Probe material</b>	
C	Tefzel, (ETFE)
<b>Fitting material</b>	
2	stainless steel 1.4571/AISI 316 Ti
<b>Connection (optional)</b>	
B	connector M 12 to DIN EN 60947-5-2
<b>Cable (type LVCC, AWG24, 3x0.2 mm<sup>2</sup>)</b>	
standard without cable	
NR150 - DC9-36V - 3/4"NPT - C - 2 - ... ordering example	

## Features

- status indication by 2 LED's
- suitable for general industrial applications
- recommended for oil or media with similar electrical conductivity
- min/max selector switch
- transistor output
- max. medium temperature +130 °C
- cable connection via cable gland PG7 or M12 connector

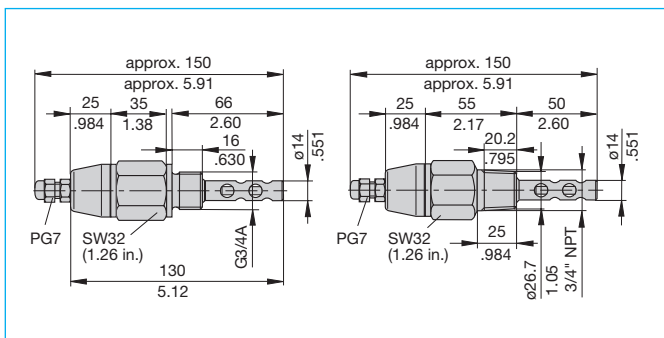



# Level Sensor NR160



Capacitive Level Sensor NR160 is designed to monitor liquids and powders with high relative dielectric constant  $\epsilon_r$ .  
With MIN/MAX selector switch.

## Features

- status indication by 2 LED's
- max. medium temperature +130 °C
- min/max selector switch
- transistor output
- recommended for granules, powder, water and other electrically conductive media
- cable connection via cable gland PG7 or M12 connector

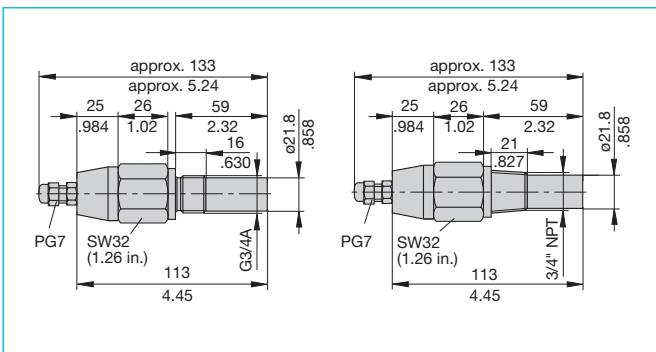

## Ordering Information

<b>Type No.</b>	
<b>NR160</b>	level sensor
<b>Voltage Rating</b>	
<b>DC 9 - 36 V</b>	short-circuit proof PNP transistor output
<b>Mounting method</b>	
<b>G3/4A</b>	thread to DIN 13, part 6, ISO 228/1
<b>3/4" NPT</b>	thread to ANSI B1.20.1
<b>Probe material</b>	
<b>A</b>	Polyamide, PA12-Gf
<b>Fitting material</b>	
<b>2</b>	stainless steel 1.4571/AISI 316 Ti
<b>Connection (optional)</b>	
<b>B</b>	connector M 12 to DIN EN 60947-5-2
<b>Cable (type LVCC, AWG24, 3x0.2 mm<sup>2</sup>)</b>	
standard without cable	
<b>NR160 - DC9-36V - 3/4"NPT - A 2 - .</b> ordering example	

## Condensed Selector Chart

ESS20 with physical isolation	<b>ESS20-0..</b>
ESS20 with remote reset input	<b>ESS20-1..</b>
Power distribution system for ESS20-0.. and ESS20-1.. modular two-way terminal blocks	<b>17PLUS-...</b>
Power distribution system for ESS20-003 4, 8, 12 or 16 channels	<b>SVS 02</b>

Electronic circuit breakers are designed to ensure selective disconnection of individual loads in systems which are powered by a DC 24 V switch-mode power supply.



## Features and benefits

- DC 24 V control voltage remains stable in the event of short circuit or overload.
- Integral switching function for start-up and maintenance work.
- Reliable switching of capacitive loads up to 20,000 µF.
- Physical isolation of load circuit ensures complete disconnection of load.
- Reliable disconnection also with high cable attenuation.
- Plug-in mounting utilising power distribution systems Module 17plus or SVS02.
- Reduces wiring time and saves space in the control cabinet.

## Protection Principle

Typical power system in a control cabinet

$$I_{total} = I_{L1}(2A) + I_{L2}(1.5A) + I_{L3}(0.5A) + I_{L4}(3.2A) + I_{L5}(5A) = 12.2A$$

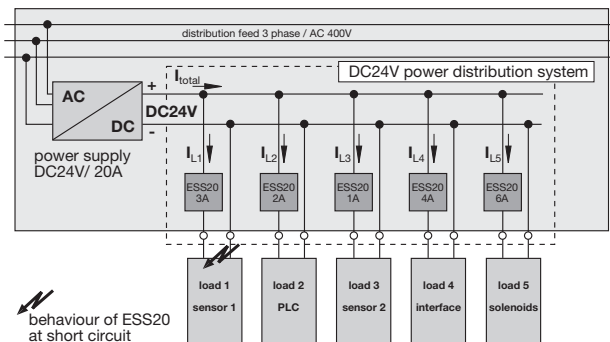

behaviour of ESS20 at short circuit

Behaviour of ESS20 at short circuit in load path 1

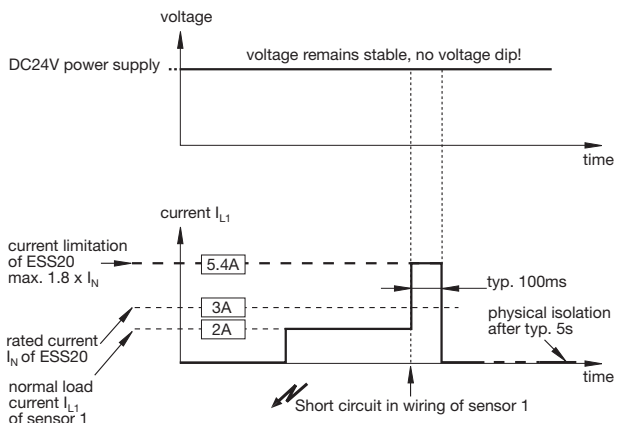



# Electronic Circuit Breaker ESS20-0/-1. for Module 17plus



## Features

- Selective load protection with physical isolation in the event of a fault.
- All types of loads can be connected (DC motors etc. on request).
- Active current limitation (1.8 times rated current) for safe connection of capacitive loads and on overload/short circuit.
- Electronic trip characteristic
- In fixed values from 1 A to 10 A and in switchable variants (1 A/2 A or 3 A/6 A).
- Manual ON/OFF button (push-push actuation)
- Clear status and failure indication
- Width per unit only 12.5 mm
- Plug-in mounting utilising power distribution system Module 17 plus.

Electronic circuit breaker type ESS20 is designed to ensure selective disconnection of individual loads in systems which are powered by a DC 24 V switch-mode power supply.

DC 24 V power supplies, which are widely used in industry today, will shut down the output in the event of an overload with the result that one faulty load in the system can lead to complete disconnection of all loads. As well as an unidentified failure this also means stoppage of the whole system.

Through selective disconnection the ESS20 responds much faster to overload or short circuit conditions than the switch-mode power supply. This is achieved by a combination of active current limitation and well-proven circuit breaker technology including physical isolation. The ESS20 limits the highest possible current to 1.8 times the set rated current of the circuit breaker. Thus it is possible to switch on even capacitive loads or lamp loads, but they are disconnected only in the event of an overload or short circuit.

For optimal adjustment to the application conditions the current rating of the ESS20 can be selected. Failure and status indication are provided by a bicolor LED and an integral signal contact. The ESS20 features a width of only 12.5 mm and can be plugged into the E-T-A power distribution socket Module 17plus, ensuring ease of installation and saving space in control cabinets.

ESS20-001-... (single signalisation N/O)

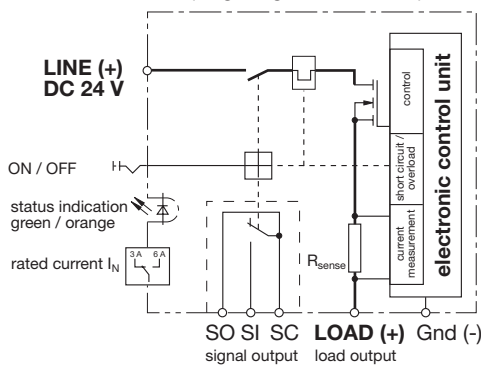

ESS20-124-...

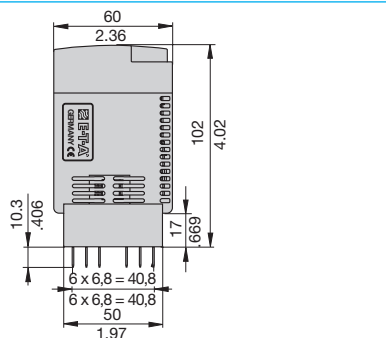
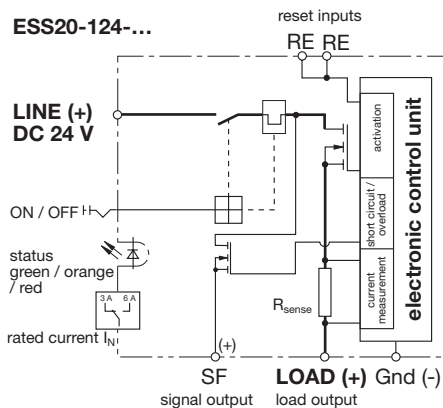

## Ordering information for ESS20-0..

<b>Type No.</b>		ESS20 electronic circuit breaker for DC 24 V applications	
<b>Version</b>		00 standard, with physical isolation	
<b>Signal output</b>		1 signal contact N/O, single signalisation	
		3 signal contact N/O, group signalisation	
<b>Input voltage</b>		DC24V rated voltage DC 24 V	
<b>Current rating</b>		1 A, 2 A, 3 A, 4 A, 6 A, 8 A, 10 A	
		1 A/2 A selectable	
		3 A/6 A selectable	
ESS20	00	3	DC24V 3 A/6 A ordering example

## Ordering information for ESS20-1..

<b>Type</b>		ESS20 Electronic Circuit Breaker with current limitation (typically 1.8 x I <sub>N</sub> or 1.5 x I <sub>N</sub> at 8 A, 10 A)	
<b>Version</b>		1 without physical isolation in the event of a failure	
<b>Control input</b>		2 with reset input RE	
<b>Signal output</b>		4 status output SF (single signalisation, plus switching)	
<b>Operating voltage</b>		DC24V rated voltage DC 24 V	
<b>Current rating</b>		1 A, 2 A, 3 A, 4 A, 6 A, 8 A, 10 A	
		1 A/2 A selectable	
		3 A/6 A selectable	
ESS20 - 1	2	4	- DC24V - 3 A/6 A ordering example (recommended type)

**Attention:** the user has to make sure that the cable cross sections of the relevant load circuit are suitable for the current rating of the ESS20 used.

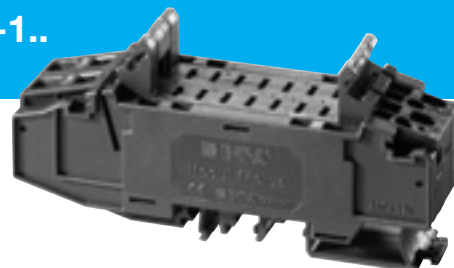

Module 17plus is a power distribution system for use with electronic circuit breaker ESS20. Each module accommodates two breakers with an individual housing width of only 12.5 mm and fits onto all industry standard mounting rails.

The two-way modules can be interconnected to provide as many ways as required with a terminal block fitted at each end for connection of signalling circuits. A distribution busbar can be fitted on the supply side of the modules (positive pole) though each pole of multipole circuit breakers must be individually connected.

Electrical connections are by means of spring-loaded terminals. The reference potential for the ESS20 (Gnd pin 11) is also looped through and connected to the terminals at the sides.

The integral make contact of the ESS20-001 (SC-SI) can be tapped at terminal 12 of the relevant channel (individual signalisation).

The ESS20-003 has an integral signal contact (change-over contact). The contact SC-SO is used for group fault signalisation. For this purpose the contacts for signalisation are connected in series in the Module 17plus and are connected to the terminal blocks via two terminals (13,14). It is possible with a test probe to contact the series connection in each module and detect possible interruptions.

All internal wirings for the ground potential and the group signal are established by the modular mounting of the individual Modules 17plus.

## Ordering information

17PLUS-Q02-00	Module 17plus, centre piece, two-way
17PLUS-QA0-LR	one each left- and right-side terminal block for supply feed from the side by means of screw terminal

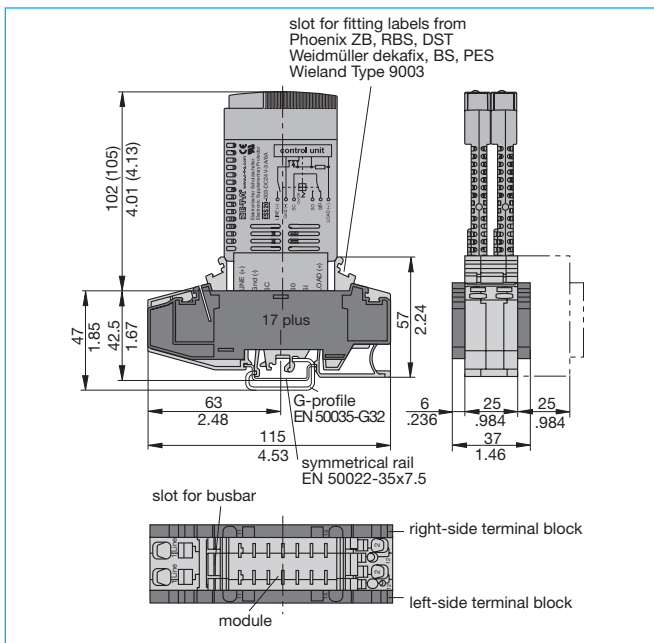

# Accessories for ESS20-03 SVS02

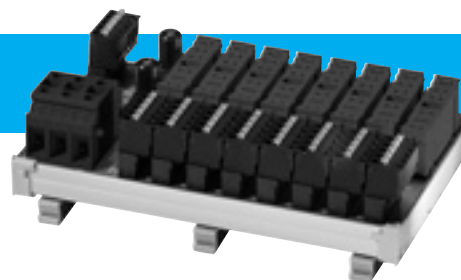

The E-T-A power distribution system SVS02 is designed to accommodate the electronic circuit breaker series ESS20-003. It distributes the current supplied by a switch mode power supply up to 40 A to 4, 8, 12 or 16 channels. Input connections are via screw terminals. The individual circuit breakers can be plugged in. Loads are connected via spring-loaded screwless terminals. The power distribution includes integral wiring of the signalisation of the individual channels which can be combined to a group signal. The SVS02 can be snapped onto a DIN symmetrical rail.

### Typical applications:

Production lines, machine tools powered by switch-mode power supplies with DC 24 V output (max. 40 A)

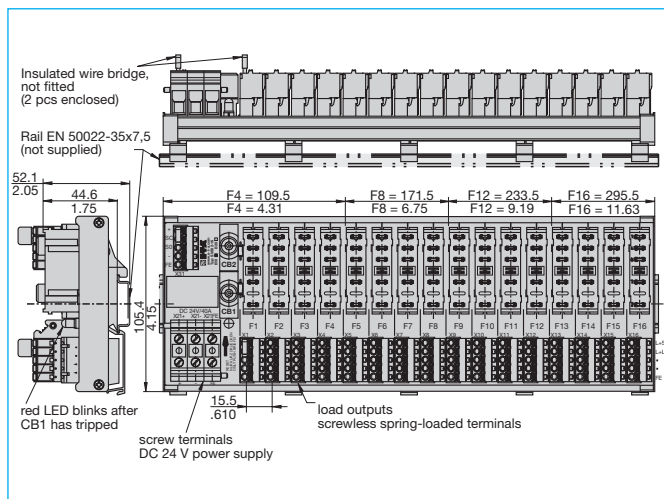

## Ordering information

<b>Type</b>	Power distribution system for ESS20-003
<b>SVS02</b>	2 insulated wire bridges Y 303 881 08 included
	<b>Version, max. number of ESS20-003 or SVS02</b>
	<b>04</b> 4 channels (F1...F4)
	<b>08</b> 8 channels (F1...F8)
	<b>12</b> 12 channels (F1...F12)
	<b>16</b> 16 channels (F1...F16)
	<b>Screw terminals for power supply DC 24 V</b>
	<b>P310</b> 3 loop-through terminals (X 21) max. 10 mm <sup>2</sup> for DC 24 V (+) / DC 24 V (-) / FE functional earth
	<b>Load outputs per channel (F1 .. Fn, n = 04, 08, 12, 16)</b>
	<b>L50</b> 5 load outputs per channel, max. 8 A each
	<b>Signal outputs</b>
	<b>S15</b> 1 signal terminal (X31) for group signal, 5-pole, complete with plug-in terminal, wiring 5 x max. 2.5 mm <sup>2</sup> / without connector sleeve, max. 0.5 A
	<b>Control input</b>
	<b>E00</b> without control input
	<b>Fitting variants</b>
	<b>B10</b> complete with Combicon screwless connectors (cage clamp), (max. 2.5 mm <sup>2</sup> , without connector sleeve) (standard)
	<b>B20</b> complete with plug-in screw terminals (max. 2.5 mm <sup>2</sup> , without connector sleeve)
<b>SVS02 - 16-P310 - L50 - S15 - E00 - B10</b>	

## Condensed Selector Chart

Solid State Remote Power Controllers (SSRPCs)

single pole:

**E-1048-6../7.. and E-1071**

double pole:

**E-1072**

Voltage ratings DC 24 V; DC 48 V

Current ratings 0.1...4.0 A

Smart Power Relay

**E-1048-8..**

single pole

Voltage ratings DC 12 V/24 V

Current ratings 1...25 A



## Features and benefits

Solid State Remote Power Controllers and Smart Power Relays

E-1048 and E-1071

- overcurrent-proof and short circuit proof switching output through electronic current limitation and overload disconnection
- electrical isolation of control and load circuit (opto-coupler)
- low control current (typically 5 mA)
- no contact burnout or welding
- 2-pole physical isolation in the event of a failure, electrically or manually (except for E-1048..)
- status and failure indication, analogue output (only E-1048-8..)

Additional features of devices with switch-mode operation (E-1071-60x):

- extended operating voltage range (max. DC 60 V)
- max. energising energy for the load
- automatic compensation of the cable resistance in the load circuit
- integral fast disconnection of load

Double pole SSRPC E-1072 for machinery and equipment, meeting the requirements of the European Machinery Directive 98/37/EG or EN60204 part 1 for machinery with ungrounded power supplies:

- double pole physical isolation in the event of a failure
- double pole electronic amplifier DC 24 V / 3A
- inrush current and short circuit current limitation
- permanent wire break monitoring

## Typical applications of SSRPCs:

- electronic replacement for electro-mechanical switching and control components
- reliable switching of magnetic valves in pneumatic, hydraulic equipment or in rail vehicles
- cable protection in larger plants (e.g. rolling mills etc.) with long cable lengths at small cross sections; conventional fuses will trip here too late due to the high cable resistance or not at all.
- permanent monitoring of load circuit for wire break
- connection to PLCs as switching amplifiers with failure indication and overcurrent protection.



The E-T-A Solid State Remote Power Controller (SSRPC) E-1048-60. is an opto decoupled transistorised switching device providing control, protection and signalisation. It may be used wherever safe switching and protection of resistive, inductive or lamp loads in DC voltage systems are required.

## Ordering information

Type No.	
<b>E-1048</b>	solid state remote power controller
<b>Version</b>	
<b>600</b>	wire break indication in OFF condition (standard)
<b>602</b>	with permanent wire break monitoring
<b>Voltage rating</b>	
<b>DC 24V</b>	DC 24V
<b>Current rating</b>	
<b>0.5 A</b>	
<b>1.0 A</b>	
<b>2.0 A</b>	
<b>4.0 A</b>	
<b>E-1048 - 600 - DC 24 V - 1.0 A</b>	ordering example

## Features

- optimum load protection
- no derating required over entire temperature range
- fast short-circuit limitation and disconnection
- time/current dependent overload disconnection (simulating thermal-magnetic CBE trip curve)
- remote control
- fault indication
- mounting on socket 17-P10-Si (accessoir)

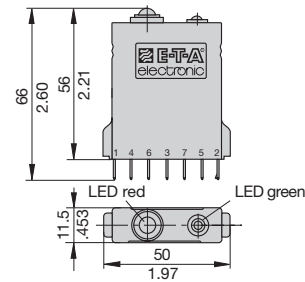

# Solid State Remote Power Controller E-1048-7..



The E-T-A Solid State Remote Power Controller E-1048-7.. is a transistorised switching device providing both protection and signalisation. It is suitable for all applications where the capabilities of the existing PLC outputs are not sufficient or where no protection against overload and short circuit or wire breakage monitoring of connected loads is provided. The use of a costly, high-capacity output card becomes superfluous when only one or two powerful outputs are necessary.

Using the SSRPC E-1048-7.. in combination with the module 17plus creates a new, very flexible system capable of being subsequently changed or extended. Busbars, pre-wired signal contacts and spring-loaded terminals reduce installation times considerably (see accessories).

## Ordering information

Type No.	
<b>E-1048</b>	SSRPC for PLC outputs
<b>Version</b>	
<b>700</b>	wire break indication in OFF condition (standard)
<b>710</b>	wire break indication in OFF condition and fault storage
<b>702</b>	permanent wire break indication
<b>712</b>	permanent wire break indication and fault storage
<b>Voltage rating</b>	
<b>DC24 V</b>	DC24 V (standard)
<b>Current ratings</b>	
<b>0.5 A</b>	
<b>1.0 A</b>	
<b>2.0 A</b>	
<b>4.0 A</b>	
<b>E-1048 - 700 - DC24 V - 1.0 A</b>	ordering example

## Features

- Optimum load protection. Available in current ratings of 0.5 A; 1 A; 2 A; 4 A. No derating required over entire temperature range!
- Fast short-circuit limitation and disconnection
- Time/current dependent overload disconnection (simulating thermal-magnetic CBE trip curve)
- Remote control
- Fault indication: LED and signal output for overload/short-circuit signalisation, and wire break indication in the OFF condition (version -700 and -710) and in the OFF and ON condition (version -702 and -712)
- Fault storage: version -710 and -712
- Physically isolated fault indication.
- Compact plug-in type
- Plug-in design for use with power distribution system module 17plus  
Integral pre-wiring of common supply and signal contacts

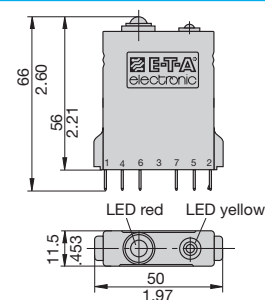

# Solid State Remote Power Controller E-1048-8C. (CUBIC) / E-1048-8I. (INLINE)



## Features

- Integral power electronics provide a wear-resistant switching function, insensitive to shock and vibration.
- Only a fraction of the control power needed by electro-mechanical relays is required for switching loads. This is important for battery buffered load circuits which have to remain controlled even with the generator off line.
- The extremely low induced current consumption of less than 1 mA is absolutely necessary for battery buffered applications.
- The load circuit is disconnected in the event of an overload or short circuit, the trip curve is also suitable for smaller motor loads.
- The load circuit is permanently monitored for wire breakage.
- Two status outputs for control signal AS and group signal SF provide status indication. For processing the actual value of the current flow in a power management system an analogue output from 0 to 5 V is provided. This voltage signal may also be used as an input to a control circuit or to switch off the unit by means of external control in the event of low load current value.
- For switching and monitoring loads of 25 A (Cubic) / 20 A (Inline) plus it is possible to connect several units in parallel. Uniform power distribution between units must be ensured by symmetrical design of the supply cables (length and cross section).
- Coloured label, e. g. red = 10 A, see ordering information.

The Smart Power Relay E-1048-8C/I is a remotely controllable electronic load disconnecting relay with three functions in a single unit:

- electronic relay
- electronic overcurrent protection
- status indication

The 7 pin CUBIC version is designed for use with standard automotive relay sockets. A choice of current ratings is available from 1 A through 25 A.

The 7 pin INLINE version is designed for use with various E-T-A terminal blocks, e.g. 17-P10-Si. A choice of current ratings is available from 1 A through 20 A. An operating voltage range of DC 9...32 V allows the connection of DC 12 V and DC 24 V loads.

In order to switch and protect loads remotely, it has until now been necessary to connect several discrete components together

- an electro-mechanic relay, control cable and integral contact to close the load circuit
- an additional protective element (circuit breaker or fuse) for cable or equipment protection
- a device for current measurement (shunt)

**Now type E-1048-8C/I combines all these functions in a single unit, thus minimising the number of connections in the circuit and thereby reducing the risk of failures.**

## Ordering information (standard)

### Type

**E-1048-8C** Smart Power Relay DC 12 V/24 V - 1 A...20 A (25 A) in CUBIC housing

**E-1048-8I** Smart Power Relay DC 12 V/24 V - 1 A...20 A in INLINE housing

### Housing / temperature range

**4** with housing CUBIC: -40 °C...85 °C (60 °C at  $I_N = 25 A$ )  
INLINE: -40 °C...85 °C (70 °C at  $I_N = 20 A$ )

### Control input

**C** with control input (+ control 8.5...32 V)

### LEDs

**0** without

**3** 2 LEDs: AS yellow, SF red

### Status output minus-switching

**A** without

**D** with AS and SF

### Contents of group fault signal SF/

### LED indication SF

**0** without

**4** short circuit / overload, wire breakage indication

### Analogue output

**V0** without

**V1** 0...5V

### Characteristic curve

**4** 200 ms (switch-off delay with overload)

### Voltage rating

**U3** DC 12/24 V

### Current ratings / colour of label

**1 A** / black

**2 A** / grey

**3 A** / purple

**5 A** / light-brown

**7.5 A** / brown

**10 A** / red

**15 A** / blue

**20 A** / yellows

**25 A** / white (CUBIC only)

**E-1048-8C 4 - C 3 D 4 V1 - 4 U3 - 20 A** ordering example

with all options: - LED indications AS/SF  
- signal outputs AS/SF  
- analogue output U (I)

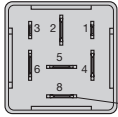

2, 4, 5, 6 and 8 - blade terminals 6.3 x 0.8  
1 and 3 - blade terminals 2.8 x 0.6

footprint to ISO 7588

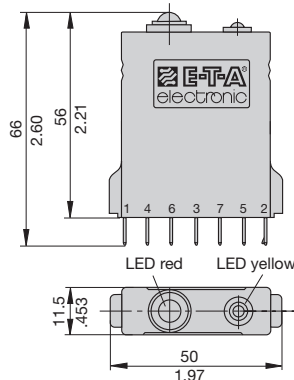
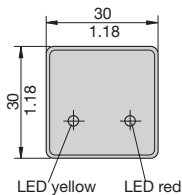
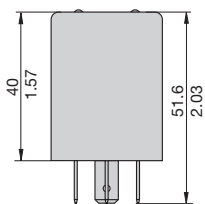



The Smart Power Relay E-1048-8D.- is a remotely controllable electronic load disconnecting relay with two functions in a single unit:

- electronic relay
- electronic overcurrent protection

The 4 pin DICE version is designed for use with standard automotive relay sockets. A choice of current ratings is available from 1 A through 25 A. An operating voltage range of DC 9...32 V allows the connection of DC 12 V and DC 24 V loads.

In order to switch and protect loads remotely, it has until now been necessary to connect two discrete components together

- an electro-mechanic relay, control cable and integral contact to close the load circuit
- an additional protective element (circuit breaker or fuse) for cable or equipment protection

**Now type E-1048-8D. combines these two functions in a single unit, thus minimising the number of connections in the circuit and thereby reducing the risk of failures.**

## Features

- Integral power electronics provide a wear-resistant switching function, insensitive to shock and vibration.
- Only a fraction of the control power needed by electro-mechanical relays is required for switching loads. This is important for battery buffered load circuits which have to remain controlled even with the generator off line.
- The extremely low induced current consumption of less than 1 mA is absolutely necessary for battery buffered applications.
- The load circuit is disconnected in the event of a short circuit (ENTRY version) or overload/short circuit (ENTRYprotect version).
- For switching and monitoring loads of 25 A plus it is possible to connect several units in parallel. Uniform power distribution between units must be ensured by symmetrical design of the supply cables (length and cross section).
- Coloured label, e. g. red = 10 A, see ordering information.

## Ordering information

Type	
<b>E-1048-8D</b>	Smart Power Relay DC 12 V/24 V, 1 A...25 A in DICE housing
<b>Housing / temperature range</b>	
<b>4</b>	with housing -40 °C...85 °C (60 °C at $I_N = 25 A$ )
<b>Control input</b>	
<b>C0</b>	with control input (+ control 8.5...32 V)
<b>Options</b>	
<b>A0</b>	without options
<b>Characteristic curve</b>	
<b>0</b>	ENTRY, short circuit protected
<b>4</b>	ENTRYprotected 200 ms standard switch-off delay with overload, short circuit protected
<b>Voltage rating</b>	
<b>U3</b>	DC 12/24 V
<b>Current ratings / colour of label</b>	
<b>1 A</b>	black
<b>2 A</b>	grey
<b>3 A</b>	purple
<b>5 A</b>	light-brown
<b>7.5 A</b>	brown
<b>10 A</b>	red
<b>15 A</b>	blue
<b>20 A</b>	yellow
<b>25 A</b>	white
<b>E-1048-8D 4 - C0 A0 - 0 U3 - 10 A</b>	ordering example: "ENTRY" version 4 pin

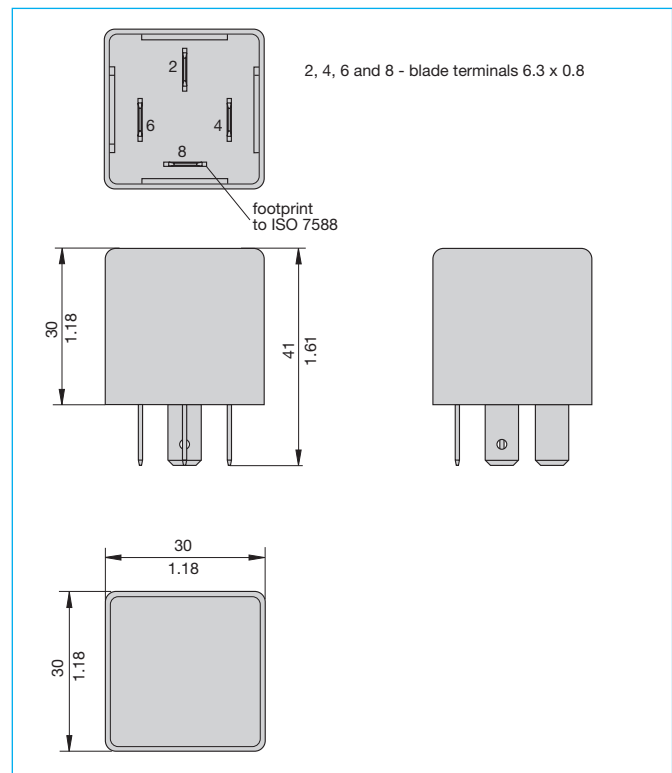



## Solid State Remote Power Controller E-1071-603



### Features

- **Designed for inductive loads (DC 24 V) e. g. solenoids**
- Individual adjustment to various load currents ( $I_N = 0.1...3.1$  A)
- Significant reduction of power loss in the load by pulse-controlled characteristics
- Short-circuit proof (short-circuit limitation); physical disconnection from supply after approx. 5 s
- Inrush current monitoring
- Physical isolation:
  - opto coupler in the control circuit
  - physical disconnection from supply
  - opto coupler for status outputs
- Reverse polarity and overvoltage protection in the control, load and status circuits
- Control current indication by YELLOW LED
- O.K. indication by GREEN LED
- Wire break indication by RED LED (load circuit)
- Fault indication by RED LED (incorrect setting etc.)
- Two status outputs for PLCs for function indication (function signal, ON signal)
- Temperature disconnection
- Quick disconnection (do not connect a free-wheeling diode to the load as the free-wheeling current is controlled electronically!)  
Break time < make time !

The E-T-A Solid State Remote Power Controllers E-1071-603/607 are electronic control modules suitable for inductive loads such as solenoids, magnetic brakes etc.

They are used

- for safe and quick switching of loads
- for monitoring the electrical condition of the loads
- for compensating different cable lengths

The load connected to the relay should be operated with a voltage higher than its rated voltage (DC 24 V) because the load current is controlled electronically (pulse-controlled characteristics). This is to ensure that in industrial plants with different cable lengths (supply cables, load cables) an increased inrush current can be applied to each load. During hold duty the load current is reduced to a smaller value (approx. 60 % of the current rating), thus reducing the operating temperature and extending the life of the loads.

### Ordering information

Type No.	
E-1071	SSRPC with power supply DC 36 V...60 V
<b>Terminals</b>	
603	screw terminals
607	screw-less connectors
<b>Voltage rating of load</b>	
DC 24 V	
<b>Current rating</b>	
0.1...3.1 A	
E-1071 - 603 - DC 24 V - 0.1...3.1 A ordering example	



## Solid State Remote Power Controller E-1072-100

### Features

- PLC controllable electronic switching amplifier (max. 3 A) with additional protective and control functions for DC 24 V loads (e.g. solenoids, magnetic brakes, electromagnetic clutches, monitoring and indicator lamps).
- Overload and short-circuit proof double pole switching output with in-rush current and short-circuit limitation.
- Electronic disconnection upon
  - an overload in the load circuit,
  - short-circuit in the load circuit,
 followed by 2 pole isolation of the load circuit (via relay contacts).
- Control input "In/Ctrl" with control current indication (YELLOW LED).
- "O.K." and availability indication (GREEN LED).
- Short-circuit and overload indication (fault indication F and RED LED).
- "Err1" group fault signalisation – all faults will be signalled:
  - wire breakage in the load circuit
  - earth fault at switching output
  - internal faults
  - overload or short circuit in the load circuit
- "Err2" fault signalisation:
  - only overload or short circuit in the load circuit
  - reset required
- Integral protection against reverse polarity and overvoltage for the control and load circuit

The E-T-A Solid State Remote Power Controller E-1072-100 is a double pole electronic switching amplifier suitable for resistive and inductive loads (solenoids, magnetic brakes etc.) as well as for lamp loads and capacitive loads.

**The double pole electronic switching output eliminates inadvertent start-up or dangerous machine movements as may arise upon a ground fault in systems with ungrounded power supply ('IT systems') (see Machinery Directive 89/392/EEC and 93/44/EEC or EN 60204 part 1, para. 9.4.3.1).**

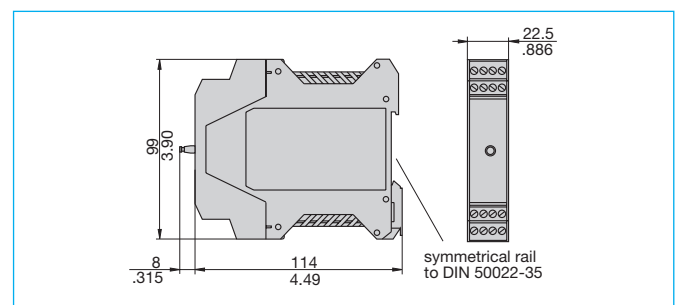

### Ordering information

Type No.	
E-1072	Solid State Remote Power Controller SSRPC
100	(trips only with overload or short circuit)
<b>Voltage rating of load</b>	
DC 24 V	
<b>Current rating</b>	
3 A	
E-1072 - 100 - DC 24 V - 3 A	